



USER'S MANUAL

Split Type Room Air Conditioner

For trouble free services please register with our Customer Care on 180030000011
or write to us at : mideacare@carriermidea.com

Please read the operating instructions and safety precautions carefully and thoroughly
before installing and operating your room air conditioner.

CONTENTS



SAFETY PRECAUTIONS	2
OPERATING INSTRUCTIONS	4
CARE AND MAINTENANCE	10
TROUBLESHOOTING TIPS	12
E-WASTE MANAGEMENT GUIDELINES	14
ANNUAL MAINTENANCE CONTRACT	15
WARRANTY TERMS & CONDITIONS	16
WARRANTY CARD	19

CAUTION



- Contact an authorized service technician for repair or maintenance of this unit.
- Contact the authorized installer for installation of this unit.
- This appliance is not intended for use by persons (including children) with reduced physical, sensory or mental capabilities, or lack of experience and knowledge, unless they have been given supervision or instruction concerning use of the appliance by persons responsible for their safety.
- Young children should be supervised to ensure that they do not play with the air conditioner.
- If the power cord is to be replaced, replacement work shall be performed by authorized personnel only.
- Installation work must be performed in accordance with the national wiring standards by authorized personnel only.

SAFETY PRECAUTIONS

To prevent injury to the user or other people and property damage, the following instructions must be followed. Incorrect operation due to ignoring of instructions may cause harm or damage. The seriousness is classified by the following indications.

 WARNING	This symbol indicates the possibility of death or serious injury.
 CAUTION	This symbol indicates the possibility of injury or damage to property.

■ Meanings of symbols used in this manual are as shown below.

	Strictly prohibited.
	Be sure to follow the instructions.

WARNING



- Do not extend the cable and never use multiple plugs. A poor electrical connection, poor insulation or voltage which is higher than permitted can cause fire.
- Do not expose your body directly to the cool air for prolonged period.
- Never poke fingers, sticks or other objects in the air inlet and outlet vents.
- Never attempt to repair, relocate, modify the air conditioner yourself. Always contact your service provider if required.
- Never pull the plug out by pulling on the cable. Hold the plug firmly and pull it out of the plug socket, otherwise there is a risk of damaging the cable.
- Do not operate your air conditioner in a wet room such as a bathroom or laundry room.



- Remove all dirt from the power plug and plug it firmly. Soiled plugs can cause fire or an electric shock.
- In the event of any abnormalities such as smell of burning, immediately switch off the device and pull the plug. Contact your service provider.
- Always switch off the device and pull the plug before you start to clean it.
- Use specified power cord.
- Contact the authorized installer for installation of this unit.
- Contact an authorized service technician for repair or maintenance of this unit.
- This appliance is not intended for use by persons (including children) with reduced physical, sensory or mental capabilities, or lack of experience and knowledge, unless they have been given supervision or instruction concerning use of the appliance by a person responsible for their safety.
- Children should be supervised to ensure that they do not play with the air conditioner.

CAUTION



- Never actuate any switches with a wet hand. It may cause an electric shock. Never use the device for any other purpose than the intended use. Never place food, precision instruments, plants, animals, paint, etc. on the unit.
- Do not expose plants or animals directly to the air flow.
- Never clean the air conditioner with water.
- Never use combustible cleaning agents as these could cause a fire or deformation.
- Never place any burning objects close to the device if they could be directly affected by the emitted air.
- Never step onto the outdoor unit and never place anything on it. Never use an unsteady or rusty base.
- Never install the air conditioner in places where combustible gas can be emitted. Emitted gas may collect and cause an explosion.
- Never allow the air conditioner to run for too long with the doors or windows open, or if the humidity is very high.



- If the air conditioner is to be used in conjunction with other heaters, the air should be refreshed periodically, otherwise there is a risk of lack of oxygen.
- Always pull out the power plug if the unit is not going to be used for any lengthy period of time. Collections of dust can cause fire.
- Always switch off the air conditioner and pull out the power plug during a storm, otherwise, electrical parts may get damaged.
- Check that the drainage line is correctly connected. If not, water will escape.
- Check that the condensation water can run off unhindered. It may cause water damage if the condensation water cannot run off properly.
- The air conditioner must be earthed in accordance with the local codes.
- For electrical safety purposes we recommend that you install an earth-leakage circuit-breaker.
- If the power cord is damaged, it must be replaced by the manufacturer, its service agent or similarly qualified persons in order to avoid a hazard.

OPERATING INSTRUCTIONS

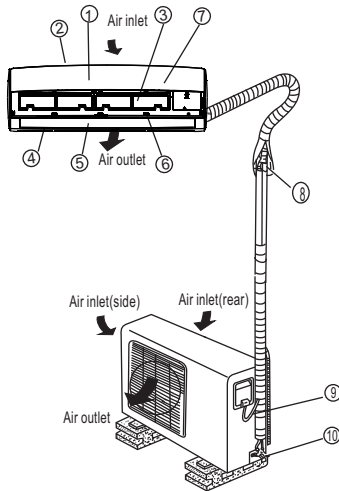

Names of parts

Indoor unit

1. Front panel
2. Air inlet
3. Air filter
4. Air outlet
5. Horizontal air flow grille
6. Vertical air flow louver (inside)
7. Display window

Outdoor unit

8. Connecting pipe
9. Connecting cable
10. Stop valve

NOTE:

All the pictures in this manual are for explanation purposes only. The actual shape of the indoor unit you purchased may be slightly different on front panel and display window. The actual shape shall prevail.

Display window



WiFi control display(optional):

Displays when the WiFi control feature is activated. (Not available when the unit does not have this function.)



Digital display:

- Displays the temperature settings when the air conditioner is operational.
- Displays the room temperature in FAN mode.
- Displays the self-diagnostic codes.
- Displays 'ON' for three seconds when Timer ON, Fresh, Swing, Turbo or Silence feature is activated.
- Displays 'OF' for three seconds when Timer OFF is set.
- Displays 'OF' for three seconds when Fresh, Swing, Turbo or Silence feature is cancelled.
- Displays 'dF' under defrosting operation.
- Displays 'cF' when anti-cold air feature is activated under heating mode.
- Displays 'SC' during self clean operation (if applicable).
- Displays 'FP' under 8°C heating operation (if applicable).
- When ECO function (optional) is activated, the '88' illuminates gradually one by one as E → C → O → set temperature → E ... in one second interval.

NOTE:

A guide on using the infrared remote is included in this literature package.

Operating temperature

Mode Temperature	Cooling operation	Heating operation	Drying operation
Room temperature	17°C~32°C (62°F~90°F)	0°C~30°C (32°F~86°F)	10°C~32°C/50°F~90°F
Outdoor temperature	18°C~43°C (64°F~109°F)	-7°C~24°C (20°F~76°F)	11°C~43°C/52°F~109°F
	-7°C~43°C/20°F~109°F: (For the models with low temperature cooling system)		18°C~52°C/64°F~126°F (For special tropical models)

NOTE:

1. Optimum performance will be achieved within these operating temperatures. when the unit operates above or below these conditions for a long time, system diagnostics may detect a malfunction and the unit will not operate properly.
2. Room relative humidity- less than 80%. If the air conditioner operates outside this range, the surface of the air conditioner may attract condensation. Please sets the vertical air flow louver to its maximum angle (vertically to the floor), and set HIGH fan mode.

Manual operation

Units are equipped with a switch to run emergency operation mode. It can be accessed by opening the front panel. This switch is used for manual operation in case the remote controller fails to work or maintenance necessary.

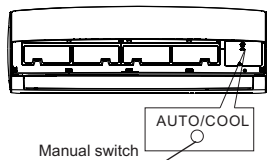

- ① Open the front panel by carefully lifting both ends at the same time. Once lifted sufficiently, a click is heard and it becomes self-supporting.
- ② Once you push the manual button, the operation mode is shifted in an order as: AUTO, COOL, OFF. The temperature will be set at 24°C/76°F and the fan on Auto.
- ③ After operation, close the panel by firmly tugging downwards on both ends until it returns to its original position.

CAUTION:

- This switch is used for testing purpose only. Please do not use it unless necessary.
- To restore the remote controller operation, use the remote controller directly.

OPERATING INSTRUCTIONS

Airflow directional control

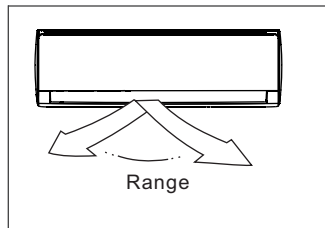
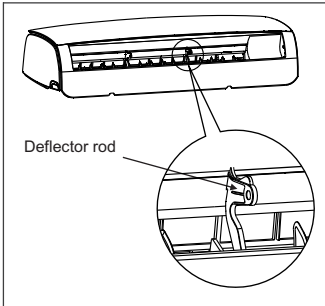
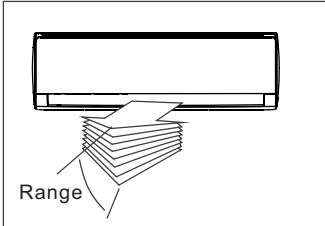

- Adjust the air flow direction properly, otherwise it might cause discomfort or cause uneven room temperatures.
- Adjust the horizontal louver using the remote controller.
- Adjust the vertical louver manually.

Adjusting vertical air flow(Up--Down)

Perform this function while the unit is in operation.

Use the remote controller to adjust the vertical air flow direction. The horizontal louver can move slightly for each press, or continuously swing up and down automatically. Please refer to the 'REMOTE CONTROLLER OPERATION MANUAL' for details.

Adjusting horizontal air flow (left - right)

- Move the deflector rod manually to adjust the air flow in the direction you prefer.

IMPORTANT: Do not put your fingers into the panel of the blower and suction side. The high-speed fan inside may cause injury.

NOTE:

Best working conditions(the energy efficiency can be affected if not set under these conditions):

- The best angle of louvers is the default angle of cooling mode
- The best way of setting the angle of louvers at heating mode is to run the unit for 5 minutes and then use the remote controller to set the louvers at the default angle of cooling mode.

⚠ CAUTION

- Do not operate the air conditioner for long periods with the air flow direction set downward in cooling or dehumidifying mode. Otherwise, condensation may occur on the surface of the horizontal louver causing moisture to drip on to the floor or on furnishings.
- After a quick restart, the horizontal louver may remain static for approximately 10 seconds.
- Open angle of the horizontal louver should not be set too small, as COOLING or HEATING performance may be reduced due to too restricted air flow area.
- Do not move the horizontal louver manually, otherwise the horizontal louver will be out of sync. But if this happens, please cease operating, unplug power for a few seconds, then restart the air conditioner.

How the air conditioner works

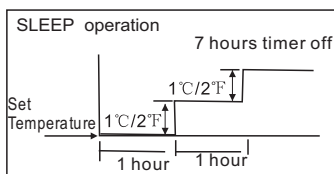

Cooling

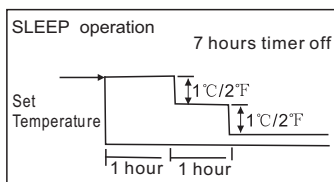

Heating

Basic operation modes: AUTO/COOL/DRY/HEAT*
(*) Model dependent

AUTO operation

- When you set the air conditioner in AUTO mode, it will automatically select cooling, heating (cooling/heating models only), or fan only operation depending on set temperature and the room temperature.
- The air conditioner will control room temperature automatically to the temperature point you set.
- If you feel uncomfortable in the AUTO mode, you can set your desired temperature.

SLEEP operation

When selected, the set temperature will increase (cooling) or decrease (heating) by 1°C/2°F per hour for the first 2 hours. Thereafter it keeps this new temperature for 5 hours before switching off.

This operation saves energy and improves night time comfort by synchronising with the body's metabolism.

DRYING operation

- The temperature is regulated while dehumidifying by repeating turning on and off of the cooling operation or fan only. The fan speed is LOW.

HEATING operation

This air conditioner operates on the heat-pump principle, absorbing heat from air outdoors and transferring that heat to the indoor unit. As a result, the operating performance is reduced as outdoor air temperature drops. If you feel that the heating performance is insufficient, we recommend you to use this air conditioner in conjunction with other kinds of heating appliance.

Optimal operation

To achieve optimal performance, please note the following:

- Adjust the air flow direction correctly so that it is not towards people.
- Adjust the temperature to achieve moderate comfort levels. Excessively low or high temperature waste energy.
- Improve performance by keeping windows and doors closed.
- Limit energy usage (run time) by using the TIMER function.
- Do not put any object near air inlet or air outlet, as the efficiency of the air conditioner may be reduced and may cause the air conditioner to stop running.
- Inspect the air filters periodically, and clean them when needed.

OPERATING INSTRUCTIONS

Special functions

Refrigerant Leakage Detection(Optional)

When refrigerant leakage is detected, the indoor unit will display 'EC' code or flash LEDs(model dependent).

Louver Angle Memory Function(optional):

Within the scope of safety angle, the horizontal louver angle is memorised and will return to the position last selected by user. If it exceeds, it will memorize the boundary of safety angle. This will not happen when Turbo or manual control buttons are pressed or after a power interruption. So we strongly suggest that the open angle of the horizontal louver should not be set too small, in case the condensed water forms and drips from the horizontal louver.

SELF CLEAN function(Optional)

- Airborne bacteria use the moisture on the indoor heat exchanger to grow. Regular drying of the exchanger prevents this growth. By simply pressing the SELF CLEAN button, the system will automatically manage the process. This cleaning action may be done as frequently as desired.
- For cooling models, only the indoor fan is active in low speed for 30 minutes and the unit turns off automatically.
- For cooling & heating models, the unit will operate as in the following sequence : FAN mode at Low fan speed--Heating operation with LOW fan speed ---FAN operation--Stop Operation---Turn off.

Note:

- This function is only activated in COOLING or DRY mode.
- Before activation the air conditioner, it is recommended to run the air conditioner under cooling operation for about 30 minutes.
- Pressing the SELF CLEAN or ON/OFF button again during the cleaning cycle will cancel the operation and turn the unit off.

CLEAN AIR function(Optional)

Improving the quality of indoor air is one of the purposes of an air conditioner. This air conditioner is equipped with ionizer or Plasma Dust Collector(model dependent). With the anions generated by Ionizer, the air circulation of the air conditioner fills the room with refreshing, natural and healthy air. The Plasma Dust Collector generates a high voltage ionization zone, through which the air is converted to plasma. Inside the air most of the dust, smoke, and pollen particles are captured by the electrostatic filter.

Anti-mildew function(Optional)

When turns off the unit on COOL, DRY, AUTO (Cool) mode, the air conditioner will continue operating for about 10 minutes (depending on models) with soft wind. This will help to dry up the condensed water inside the evaporator, and prevent the mildew growth. Under Anti-mildew operation, do not restart the air conditioner until the unit is completely off.

Auto-restart function(Optional)

In event of power interruption such as a blackout, the air conditioner stops once. But it restarts automatically and performs previous operation when the power supply is resumed.

WIFI Control Function(optional)

For the unit with WIFI control function, connect the WIFI module and communication module with display board, so the unit can be controlled either by remote controller or by mobile telephone.

Air Filter Reminding Function(optional)

Cleaning filter reminding function:

After 240 hours of operation, the indoor display window will display and flash 'CL', this feature is a reminder to clean the Air Filter for more efficient operation. After 15 seconds, the system will revert back to the previous display again. When the 'CL' indicator appears and flashes, please press the LED button on remote controller for 4 times or press the Manual control button for 3 or more times to clear the registered hours, otherwise the 'CL' indicator will display and flash again for another 15 seconds at the next time of starting the unit.

Replacing filter reminding function:

After 2880 hours of operation, the indoor display window will display and flash 'nF', this feature is a reminder to replace the Air Filter for more efficient operation. After 15 seconds, the system will revert back to the previous display again. When the 'nF' indicator appears and flashes, please press the LED button on remote controller for 4 times or press the Manual control button for 3 or more times to clear the registered hours, otherwise the 'nF' indicator will display and flash again for another 15 seconds at the next time of starting the unit.

Mute operation(optional)

Press the LED button on the remote controller can turn off the indoor screen display, and also turn off the Air conditioner buzzer, which create a comfortable and quiet environment.

CARE AND MAINTENANCE

Care and Maintenance

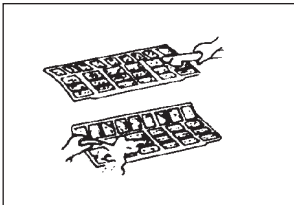
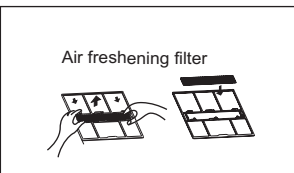
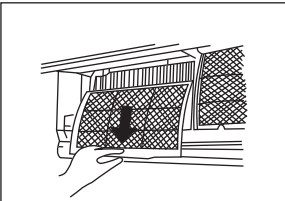
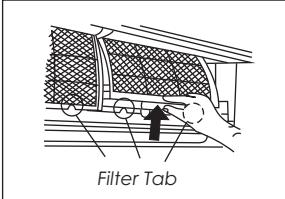
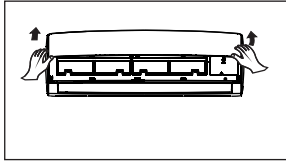

Before maintenance

- Turn the system off before cleaning. To clean, wipe with a soft, dry cloth. Do not use bleach or abrasives.

NOTE: Power supply must be disconnected before attempting to clean or service!

⚠ CAUTIONS

- Do not use a chemically treated cloth or duster to clean the unit.
- Do not use benzine, thinner, polishing powder, or similar solvents for cleaning. These may cause the plastic surface to crack or deform.
- Never use water hotter than 40°C/104°F to clean the front panel, it could cause deformation or discoloration.

Cleaning the unit

wipe the unit with a soft dry cloth only. If the unit is very dirty, wipe it with a cloth soaked in warm water.

Cleaning the air filter and air freshening filter

A clogged air filter reduces the cooling efficiency of this unit. Please clean the filter once every 2 weeks.

1. Open the front panel by carefully lifting both ends at the same time. At a certain angle, a clicking sound is heard and it becomes self-supporting. For some models, please use the suspension bars to prop up the panel.
2. Use the tab provided to move the filter first up a little, then slightly towards you. Now extract the filter by gently drawing downwards.
3. Unclip the small air freshening filter from the large air filter. Clean it with vacuum, and replace it occasionally.
4. Clean the large air filter with soapy water. Rinse with fresh water. Shake off excess water and dry it up in cool place, replace it occasionally.

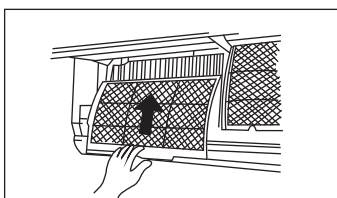
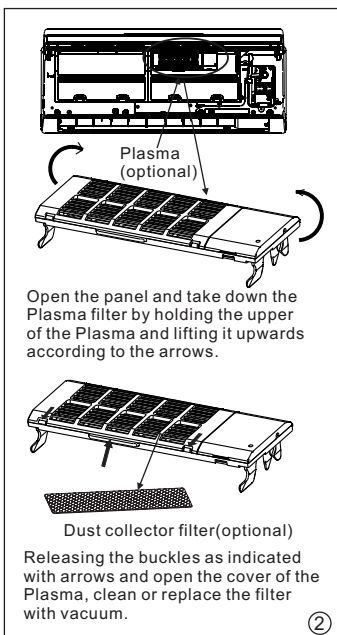

△ For the models adopts Plasma, do not touch the plasma within 10 minutes after you open the panel. Clean the Plasma according to the description in the figure left.

5. Refit the small air freshening filter onto the large air filter.
6. Re-insert into unit in the reverse order described in point 2 above.
7. Close the front panel. Make sure the buckles are fully fit and the panel is completely closed.

Preparation for extended non-operation

If you plan to idle the unit for a long time, perform the following:

- (1) Clean the indoor unit and filters.
 - (2) Operate the fan for about half a day to dry the inside of the unit.
 - (3) Stop the air conditioner and disconnect power.
 - (4) Remove the batteries from the remote controller.
- The outdoor unit requires periodic maintenance and cleaning. Do not attempt to do this yourself. Contact your dealer or service provider.

Pre-season inspection

- Damaged or disconnected wires.
- Clean the indoor unit and filters.
- Check water or oil leaks.
- Check if the air outlet or inlet is blocked after the air conditioner has not been used for a long time.

⚠ Caution

- Do not touch the metal parts of the unit when removing the filter. Injuries can occur when handling sharp metal edges.
- Do not use water to clean inside the air conditioner. Exposure to water can destroy the insulation, leading to possible electric shock.
- When cleaning the unit, first make sure that the power and circuit breaker are turned off.
- Do not wash air filter with hot water at more than 40°C/104°F. Shake off moisture completely and dry it in the shade. Do not expose it directly to the sun or it may shrink.

TROUBLESHOOTING TIPS

Troubleshooting tips

The following events may occur during normal operation, and may not indicate malfunction.

Symptom	Cause
Operation is delayed after restart	To prevent blowout of the fuse, the compressor will not operate while the protection circuit is working for about 3 minutes after sudden OFF--ON operation of the power supply.
Fan speed changes-off, very slow and then normal	Automatically happens in heating mode : --prevents cold air blowing onto occupants when the heating operation is start, --perform automatic defrosting operation, --perform low temperature heating operation
Heating operation stops suddenly and defrost-light blinks	In HEAT mode, the indoor unit temporarily stops for maximum of 10 minutes to perform the automatic defrosting operation.
Mist coming out of the indoor unit	In COOL mode, a mist generated by condensation formed with sudden cooling process may be emitted.
	Mist may generate due to moisture generated from defrosting process when the air conditioner restarts in HEAT mode operation after defrosting.
Low volume sounds are emitted by the air conditioner	Hissing sound-- during operation or immediately after stopping the air conditioner, refrigerant flowing sound may be heard.
	Squeaking sound-- normal expansion and contraction of plastic and metal parts caused by temperature change during the operation.
	Rushing air-- when louver resets its position.
Dust discharges from the unit	May occur when air conditioner is used for the first time or has not been used for a long time.
Emits a peculiar odour	Various smells generated from interior textile, furniture, or cigarette smoke absorbed into the air conditioner may be emitted. If not the case call your suitable contractor.
Changes to fan only while cooling or heating mode	Room temperature reaches the temperature setting of the remote control. If not the case call your suitable contractor.
Operation is erratic, unpredictable or unresponsive	Interference from cell phone towers and remote boosters may cause the unit to malfunction
	Disconnect the power and then re-connect.
	Press the ON/OFF button on the remote controller to restart operation.

NOTE: If the problem is not resolved, please contact a local dealer or the nearest customer service center. Be sure to inform them of the detailed malfunctions and unit model number.

Troubleshooting guide

Before you call for or request servicing, troubleshoot a problem by performing following checks:

Symptom	Diagnostic
Unit will not operate	-- Is there a power failure?
	-- Has a switch been turned off, a circuit breaker tripped or a fuse blown?
	-- Is the timer operating?
	-- Are the batteries used in the remote controller exhausted?
	-- Are the batteries used in the remote controller loaded properly?
Poor cooling or heating performance	-- Are the air filters dirty?
	-- Is air flow unrestricted in & out of indoor & outdoor units?
	-- Are the temperature and mode settings correct?
	-- Are the windows or doors left opened?
	-- Is fan speed on high and louvers allowing maximum flow?
	-- Is direct or strong sunlight shinning into the room in cooling operation?
	-- Are there other heating apparatus or computers operating, or too many people in the room in cooling operation?
-- Is the "SILENCE" function is activated? Under "SILENCE" operation, noise reduction is prioritized and the air-conditioning performance may become lower.	
Indicator lamps continue flashing	-- The unit may stop operation or continue to run in a safety condition (depending on models). Waiting for about 10 minutes, the fault may be recovered automatically, if not, disconnect the power and then connect it in again. If the problem still exists, disconnect the power and contact the nearest customer service center.
Error code appears in the indoor unit, such as: E0,E1,E2.... P1,P2,P3.....or F1, F2, F3.....	

If the problem persists even if you perform these checks or diagnostics, immediately stop operation and contact the authorized service center. Be sure to inform them of the detailed malfunctions and unit model number.

 **CAUTION**

In the case of ANY of the following, turn off the unit immediately!

- Power cord is damaged or abnormally warm.
- Burning odours are smelled.
- Loud or abnormal sounds are heard.
- A power fuse blows or a circuit breaker trips frequently.
- Water or other objects fall into or out of the unit.

 **DO NOT ATTEMPT TO CORRECT THESE ITEMS YOURSELF!
CONTACT A AUTHORIZED SERVICE PROVIDER!**

E-WASTE MANAGEMENT GUIDELINES



E-WASTE MANAGEMENT GUIDELINES (PERTAINING TO THE E-WASTE RULES)

PROPER HANDLING AND/OR RECYCLING OF THE AIR CONDITIONER

Under the E-Waste (Management & Handling) Rules, 2011 (hereafter referred to as the "E-Waste Rules"), it is incumbent for all consumers, including the purchaser of this air-conditioner, to properly recycle and dispose of all electrical and electronic equipment through authorized recyclers.

E-Waste has been defined as "waste electrical and electronic equipment, whole or in part or rejects from their manufacturing and repair process, which are intended to be discarded".

E-Waste contains various hazardous materials like lead, mercury, cadmium, hexavalent chromium, polybrominated biphenyls and polybrominated diphenyls ethers. Hence, improper handling and disposal of e-waste releases these hazardous material in the environment causing pollution, contamination of soil and water and various health hazards.

Though the product purchased by you is ROHS compliant and does not contain any hazardous material above the prescribed limit under the E-Waste Rules, it is imperative that the product should be handled with utmost caution and as per the guidelines mentioned in this manual including the following Do's and Don'ts –

Do's	Don't's
Hand over the E-Waste to the Authorised Recycler.	Never sell the e-waste to any unauthorized agencies, scrap dealer/kabadiwalahs.
E-Waste should be segregated from household and other wastes.	Never throwing E-Waste in bins as part of household waste.
Keep the product in isolated area, after it becomes non-functional/un-repairable so as to prevent its accidental breakage.	Never keep E-Waste in open and exposed area, accessible by all.
The product should be opened only by authorised service personnel.	The product should not be opened by the user himself/herself. Dismantling of e-waste by the user can be dangerous.

The following marking/symbol on the product or carton indicates that the product and its accessories/parts (e.g. remote controller, batteries, spare parts etc.) should not be disposed of with other household waste at the end of their working life. Please separate these items from other types of waste and recycle them responsibly for conservation of the environment and collective well-being.



E-WASTE RECYCLING PROGRAM

We have tied up with government approved e-waste recycler for facilitating the collection of e-waste from our channel partners and customers for recycling. You are simply required to call our toll free number **1800 30 00 00 11** and register your request for collection of e-waste. Once your request is received, the representatives of the authorized recycler would collect the e-waste from your house/premises after paying the value of the same to you. For more details and information on our E-Waste Recycling Program kindly visit our website www.carriermidea.com.

ANNUAL MAINTENANCE CONTRACT

Our air conditioners contain various components and inputs that are technical in nature and it is important that any repair or replacement of any of the components of the air conditioners is done only by the personnel authorized by Carrier.

We at Carrier Midea India Pvt. Ltd. believe in providing our valued customers the best in engineered technology & quality performance for extreme Indian conditions. Striving to keep our commitments and to ensure best product performance, We offer to you exciting "Happy Homes Annual Maintenance plans" to cover the service support for your products.

We recommend that you avail Happy Homes annual maintenance services from us in order to optimize the performance and the life span of your conditioners and also to ensure their safe and proper handling.

You can contact us on our call center number 180030000011, 8am to 8pm to register your request for Annual Maintenance services or you can write to us on mideacare@carriermidea.com

WARRANTY TERMS AND CONDITIONS

WARRANTY TERMS & CONDITIONS

CARRIER MIDEA INDIA PRIVATE LIMITED (hereinafter referred to as the "Company"), hereby warrants to the original domestic purchaser (here in after called the "Purchaser") of the air-conditioning unit (as detailed within the Warranty Registration Card and here in after referred to as the "said unit") that the said unit is free from defects in materials and workmanship under normal use and service and under specified voltage conditions, and that during a period of twelve (12) months commencing from the date of invoice, as provided in the Warranty Registration Card, the Company undertakes to repair or to replace as it deems fit in sole discretion, free of charge, any part or parts of the said unit (including the compressor, condenser and evaporator) which proves to be defective in materials or workmanship.

FIVE YEAR COMPRESSOR WARRANTY

For four (4) years following the expiration of the entire unit warranty, the Company shall continue to warrant the compressor to be free from defects in material and workmanship under normal use and service and under specified voltage conditions. The Company shall repair or replace without cost to the original purchaser, any part or portion of the compressor, which shall be returned to us, transportation charges prepaid and which on inspection shall be shown to be thus defective. Expendable items like refrigerant gas, overload, oil, dryer, strainer and others are excluded from this warranty and are on chargeable basis. This warranty is subject to use of air-conditioner with input voltage of 230 V +/-10%. We recommend use of approved make of voltage stabilizer with output voltage of 230 V +/-10%. The terms and conditions as set out below shall form the basis of this warranty:

1. The warranty shall be valid and that the Purchaser can have the benefit of this warranty, if and only if the Purchaser has duly intimated the fault to the Company or its authorized dealer and that the unit is in the possession of and is used by the Purchaser.
2. The Warranty will shall be valid only for the said period of twelve months as specified above, irrespective of whether the said unit has been in use or not for any reason whatsoever, or the unit is moved from one location to another. The warranty period specified above shall include time taken for repairs, replacements, testing of unit, technical breakdowns, transit time etc. This warranty shall automatically expire by efflux of time on completion of the period indicated herein above and no notice of such expiry will be given by the Company.
3. This warranty shall stand automatically terminated in the event of the said unit being serviced, repaired, installed, de-installed, re-installed or otherwise attended to by and person or organization or agency or by the said purchaser himself (by whatever name called), other than the authorized representative / Dealer of the Company.
4. Parts of the units replaced or repaired under the terms of this warranty are warranted only for the remaining period of the original warranty period.
5. For attending any service call under this warranty beyond the Municipal limits of the locality in which the authorized representative/dealer is situated (outstation locations), all to and fro traveling and other incidental expenses as prevailing from time to time incurred in connection with the visit of the service personnel, technicians etc., shall be borne by the Purchaser and shall be payable in advance.

WARRANTY TERMS AND CONDITIONS

Additionally, all expenses incurred by the authorized representative/dealer in collecting the unit or any part thereof from such outstation locations and its return to the original location shall be borne exclusively by the Purchaser.

6. Any loss of refrigerant caused due to sabotage, improper handling or treatment, carelessness, accident, fire, flood, earthquake or any act of God, or any corrosive action on the original refrigerant pipes, fittings, valves etc. for whatever reason, shall not be covered under this warranty.
7. In the event of any change in the location of the unit, during the warranty period, this warranty shall become null and void unless the fact of the proposed change is communicated in writing to the authorized dealer at least seven (7) days prior to the said change. On receipt of such information, the authorized dealer or any of its counterparts shall arrange for de-installation of the said unit on a chargeable basis. However, it is expressly stated that in the event of any damage occurring to the unit or to any of its parts during the course of its transit by the Purchaser, repair or replacement of the said unit or any part thereof so damaged shall not be covered by this warranty.
8. While the Authorized Dealers/Company will make every effort to carry out repairs/replacement of parts under this warranty as soon as the complaint is received, it is expressly made clear that the Authorized Dealer/Company shall not be liable to do so within any specified period of time.
9. It shall be absolute discretion of the Company to (a) effect the repairs or replacement of parts whether at the site of installation or at any service center; and (b) have the job attended to either by the Company's service personnel or of its authorized dealers.
10. This warranty is in the nature of and for the purposes as set forth herein above and in particular, the Company shall not in any event be liable for any direct, indirect, incidental or consequential loss or damages to either the said purchaser and/or his property or any other third party in course of attending to any complaint.
11. Limitation of Warranty: Company shall not be responsible for providing any warranty under the following situations:
 - i. any damage caused by accident, mishandling, tampering with installation, or negligent in following instructions of the user manual issued by the Company.
 - ii. any damage caused by power surges and dips, improper electrical circuit outside the unit or by any defective electrical supply.
 - iii. at any time, during the currency of the warranty period, if any part of the unit is tampered with, altered, repaired or serviced by any unauthorized person, not being the authorized representative of the Company or its authorized dealers.
 - iv. the serial number on the unit or any part thereof is damaged, defaced, altered, obliterated, or tampered with or removed for any reason whatsoever.
 - v. the unit is unauthorizedly removed from its original place or installation or reinstallation.
 - vi. Condenser and Evaporator is found defective if the air conditioner is installed near the muddy sewages because toxic gases are harmful for the AC.
 - vii. Damage to the product due to operation in an abnormally corrosive alkaline / acidic atmosphere.

WARRANTY TERMS AND CONDITIONS

12. None of the employees and/or Authorized dealers of the Company have the authority whatsoever to vary the terms and conditions of this warranty.
13. This warranty shall be deemed to have been issued at Gurgaon in the State of Haryana, and Courts at Gurgaon shall have exclusive jurisdiction on matters covered by or following from this warranty, and the Purchaser alone shall have cause of action arising out of the transaction.

WARRANTY

Carrier Midea India Private Ltd.

Customer Copy

Model :

NAME OF CUSTOMER :

ADDRESS :

Sr. No. of the Unit :

Sr. No. of the Compressor :

Invoice No. :

Date of Purchase :

Name & Address of the Dealer :

Signature of the Dealer with seal :



..... >✂<

WARRANTY

Carrier Midea India Private Ltd.

Midea Copy

Model :

NAME OF CUSTOMER :

ADDRESS :

Sr. No. of the Unit :

Sr. No. of the Compressor :

Invoice No. :

Date of Purchase :

Name & Address of the Dealer :

Signature of the Dealer with seal :



WARRANTY CARD

PRODUCT WARRANTY CERTIFICATE

CARRIER MIDEA INDIA PRIVATE LIMITED (company) warrants this MIDEA Room air conditioner to the original purchaser to be free from defects in material and workmanship under normal use and service and under specified voltage conditions and we shall, within one year from the date hereof, repair or replace any defect without cost to the original purchaser, a part or portion thereof which shall be returned to us, transportation charges prepaid, and which on inspection by the Company shall be shown to be thus defective. Plastic parts beyond the date of delivery, fuses, air filters, refrigerants, all and other expandable items are excluded from this warranty.

FIVE YEAR COMPRESSOR WARRANTY

For four (4) years following the expiration of the entire unit warranty, the Company shall continue to warrant the compressor only to be free from defects in material and workmanship under normal use and service and under specified voltage conditions. The Company shall repair or replace without cost to the original purchaser compressor, any part or portion of the compressor, which shall be returned to the Company, transportation charges prepaid and which on inspection shall be shown to be thus defective. Expendable items like refrigerant gas (which is required to be filled in again mandatorily at the time of repairing or replacing the compressor), overload, oil, dryer, strainer and others are excluded from this warranty and are on chargeable basis.

These warranties, however, shall not apply if the room air-conditioner has been installed in a manner affecting the efficiency or performance, or if the room air-conditioner has been tampered with, altered or in any way, repaired, serviced or worked on by anybody other than the Company's own technicians/staff or its authorized representative. This warranty shall also NOT apply to the compressor which has the serial numbers altered, defected or removed. The company shall not be liable for any injury, loss, or damage (direct, indirect, or consequential) of whatsoever arising out of the use or inability to use the product.

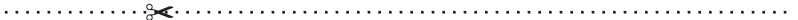

PRODUCT WARRANTY CERTIFICATE

CARRIER MIDEA INDIA PRIVATE LIMITED (company) warrants this MIDEA Room air conditioner to the original purchaser to be free from defects in material and workmanship under normal use and service and under specified voltage conditions and we shall, within one year from the date hereof, repair or replace any defect without cost to the original purchaser, a part or portion thereof which shall be returned to us, transportation charges prepaid, and which on inspection by the Company shall be shown to be thus defective. Plastic parts beyond the date of delivery, fuses, air filters, refrigerants, all and other expandable items are excluded from this warranty.

FIVE YEAR COMPRESSOR WARRANTY

For four (4) years following the expiration of the entire unit warranty, the Company shall continue to warrant the compressor only to be free from defects in material and workmanship under normal use and service and under specified voltage conditions. The Company shall repair or replace without cost to the original purchaser compressor, any part or portion of the compressor, which shall be returned to the Company, transportation charges prepaid and which on inspection shall be shown to be thus defective. Expendable items like refrigerant gas (which is required to be filled in again mandatorily at the time of repairing or replacing the compressor), overload, oil, dryer, strainer and others are excluded from this warranty and are on chargeable basis.

These warranties, however, shall not apply if the room air-conditioner has been installed in a manner affecting the efficiency or performance, or if the room air-conditioner has been tampered with, altered or in any way, repaired, serviced or worked on by anybody other than the Company's own technicians/staff or its authorized representative. This warranty shall also NOT apply to the compressor which has the serial numbers altered, defected or removed. The company shall not be liable for any injury, loss, or damage (direct, indirect, or consequential) of whatsoever arising out of the use or inability to use the product.



For more details please contact Carrier Midea India Pvt. Ltd.:

REGISTERED OFFICE : 1st Floor, Pearl Tower, Plot No. - 51, Institutional Area, Sector - 32, Gurgaon, Haryana

SALES OFFICES: Gurgaon: 0124-4707333, 4707311, Ghaziabad: 0120-4183260, Chandigarh: 0172-5007548-50, Jaipur: 0141-4109080, Mumbai: 022-26528989, 42188800, Pune: 020-41051000, Goa: 0832-2447028, Ahmedabad: 079-40267777, Kolkata: 033-40201300, Chennai: 044-42222888, Bangalore: 080-43442000, Patna: 0612-2323517, Hyderabad: 040-45462888, Cochin: 0484-4029001, Lucknow: 0522-4158710, Indore: 0731-4294700, Pondicherry: 0413-2226676, Coimbatore: 0422-4385400, Guwahati: 0361-2666077, Bhubaneshwar: 0674-2585893, Nagpur: 0712-6453790, Ranchi: 0651-6452488, 2330095, Raipur: 0771-4013245.

Visit us at : www.carriermideaindia.com

202000192726